



proasur



EXPO³

www.proasur.com

INNOVACIÓN Y VERSATILIDAD

Novedoso sistema, versátil, ligero y modular.

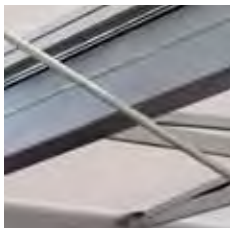

POSIBILIDAD DE ITINERANCIA

Elemento expositivo dotado de una elevada movilidad.



DISEÑO PERSONALIZABLE

Gracias a nuestro departamento de diseño junto con el cliente.

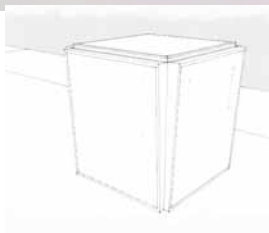

FÁCIL TRANSPORTE

Manipulación y desplazamiento mediante camión pluma y/o carretilla elevadora.



RÁPIDA COLOCACIÓN Y MONTAJE

El sistema se despliega y recoge con un solo operario.



DIMENSIONES Y PESO

Planta cuadrada de 2400 mm x 2400 mm.

Altura de 2400 mm.

Peso total de 1200 kg.

El **EXPO³** está formado por un bastidor principal de acero sobre el que se articulan los demás elementos móviles mediante bisagras y amortiguadores de empuje a gas.

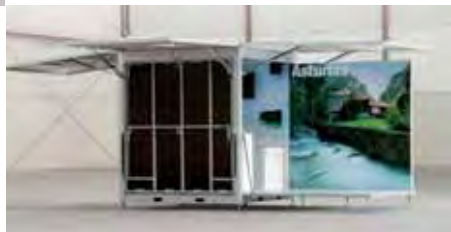

ACCESIBLE

La posibilidad de colocación de una rampa adosada en la zona central permite el acceso a personas con movilidad reducida.

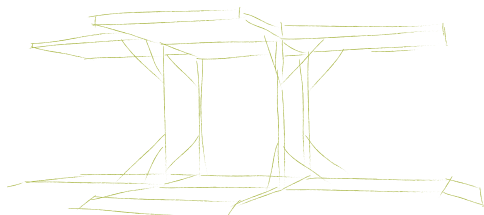

EXPO³



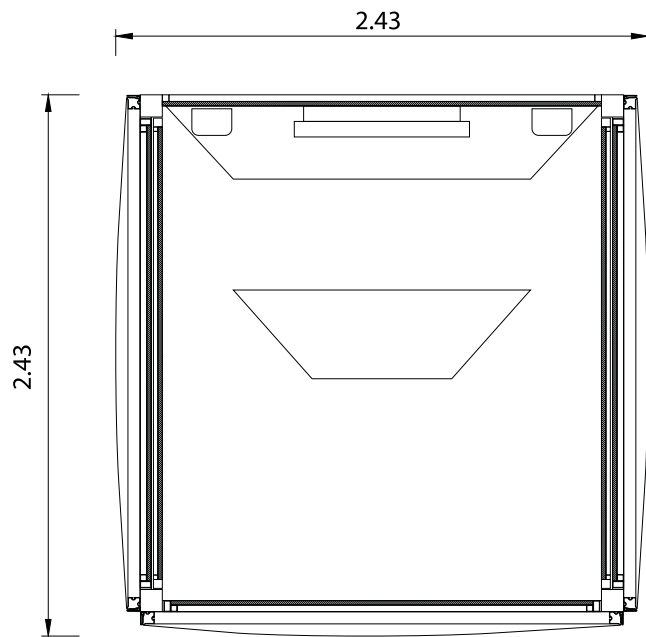

PLANTA GENERAL
CERRADO

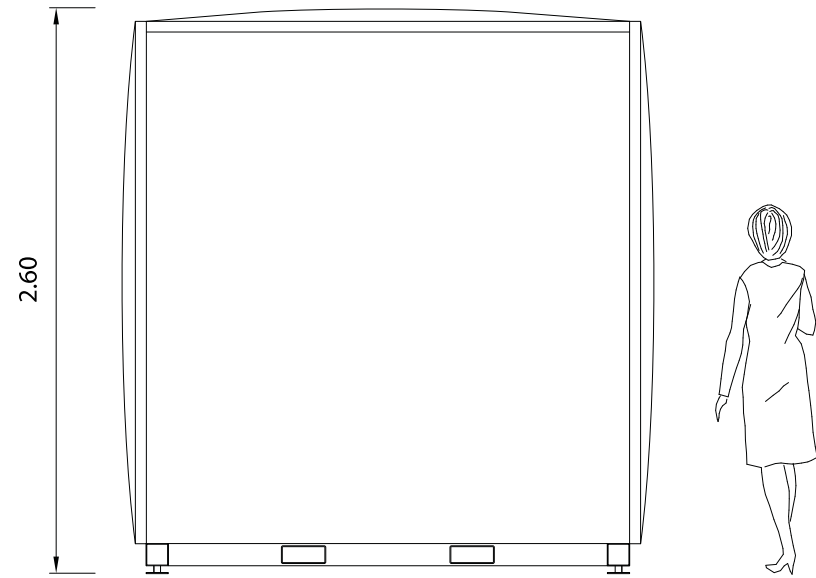

ALZADO GENERAL
CERRADO

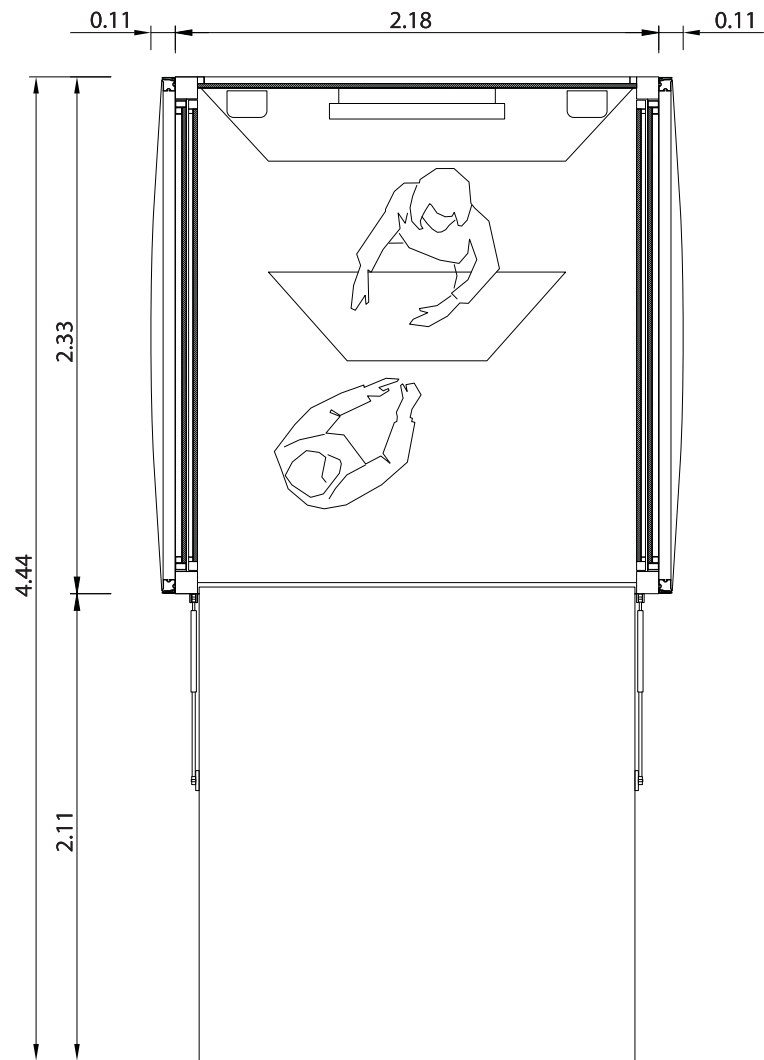

PLANTA GENERAL
ABIERTO

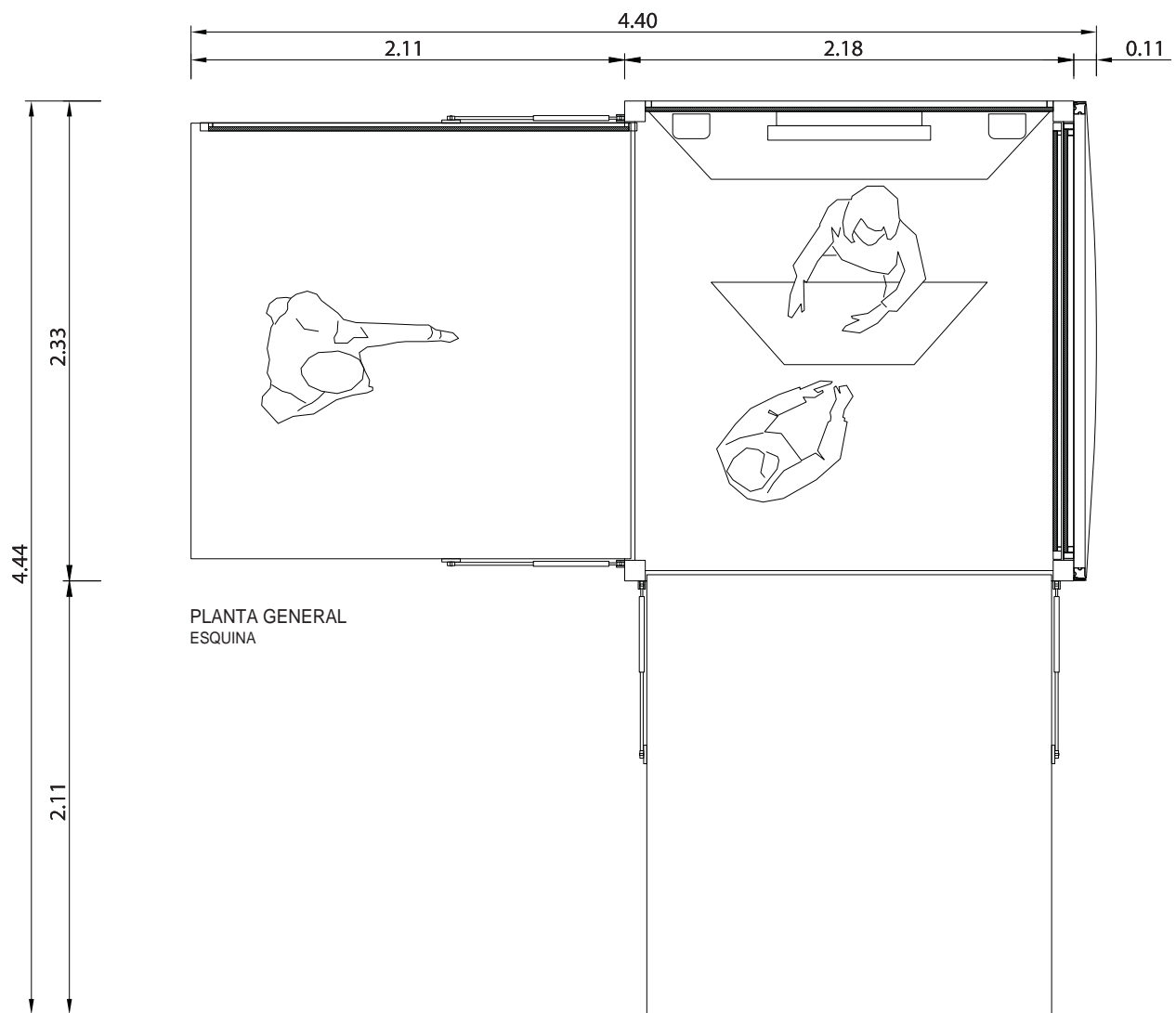

PLANTA GENERAL
ESQUINA

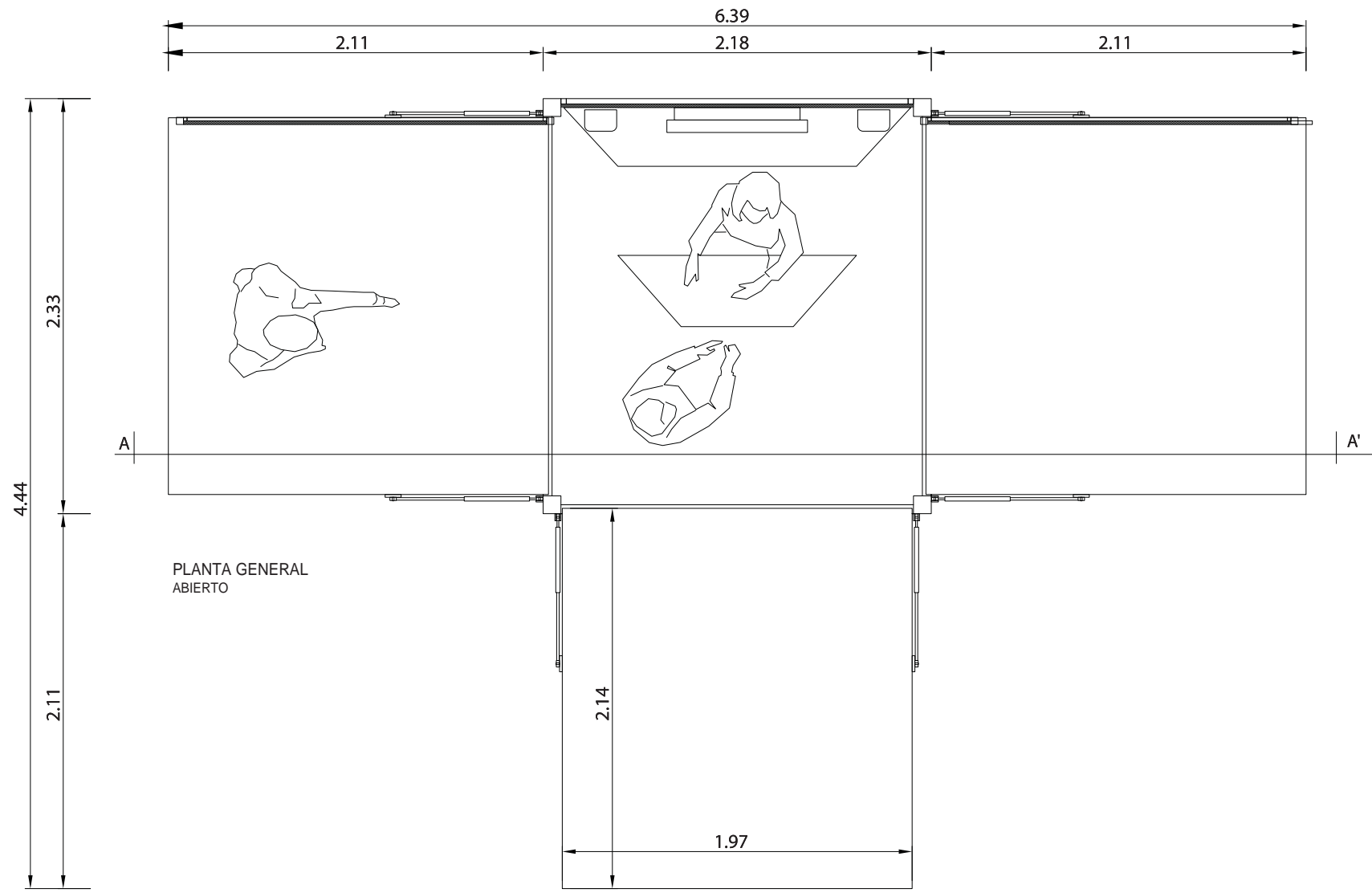

PLANTA GENERAL
ABIERTO

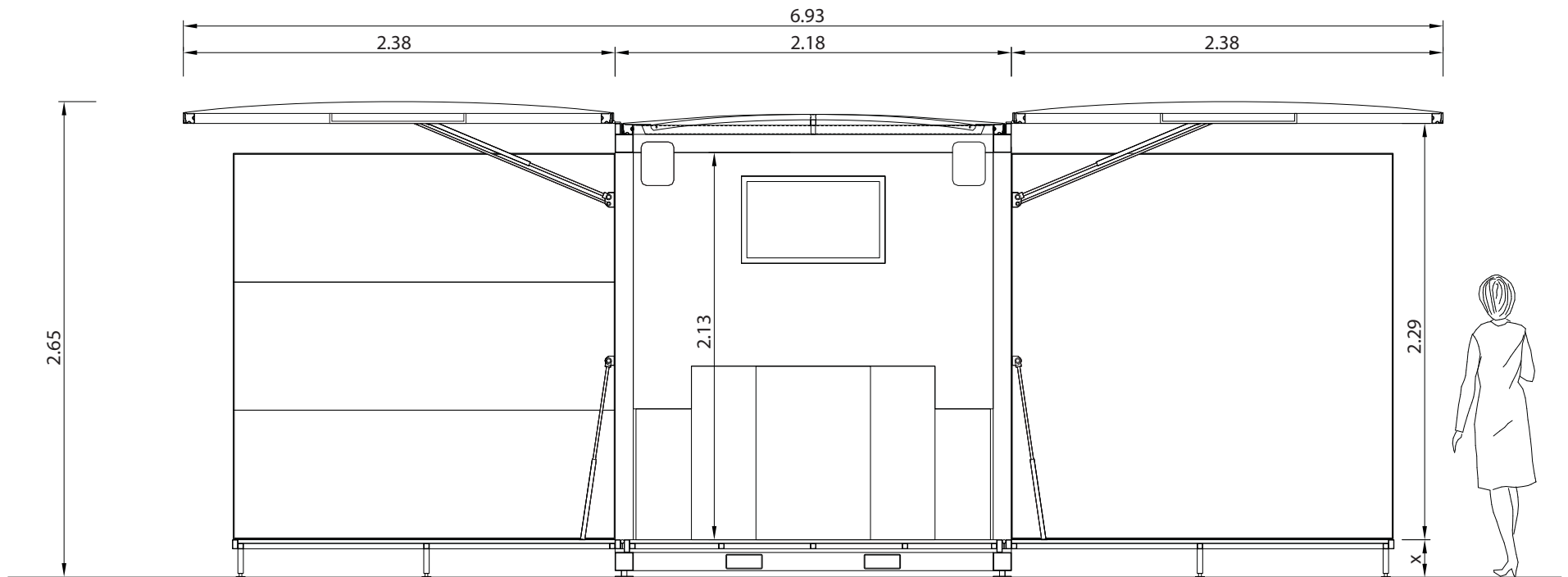

SECCION A-A'



Opción 1



Opción 2



Opción 3



Frente y lateral



Lateral y trasera



Elevar techo 1



Bajar suelo 1



Desplazar panel lateral 1

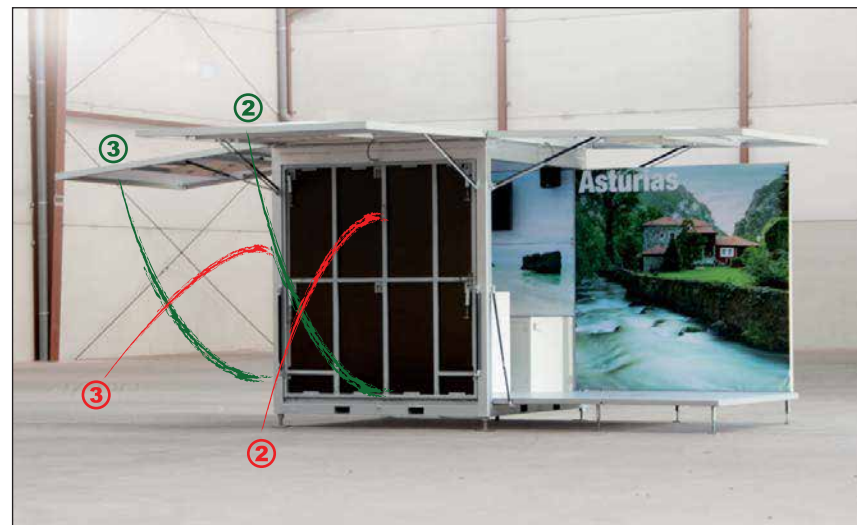

Elevar techos 2-3 y bajar suelos 2-3



Desplazar panel lateral 2



Fin del montaje



Frontal



Trasera







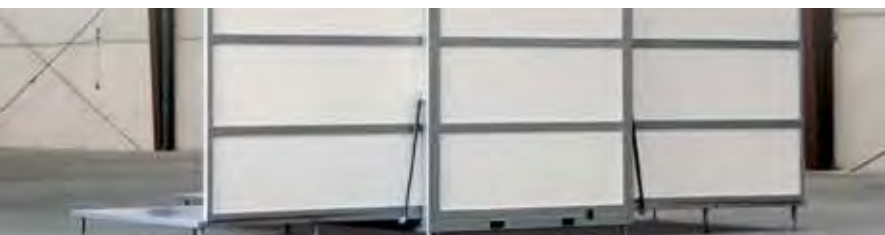

proasur

Polígono de Olloniego, Parcela B-41
33660 Olloniego, Oviedo, Asturias, Spain

info@proasur.com www.proasur.com

T (+34) 985 79 00 22 / F (+34) 985 79 00 01

